	DEPARTMENT OF FARM MACHINERY AND POWER ENGINEERING COLLEGE OF AGRICULTURAL ENGINEERING AND TECHNOLOGY CCS HARYANA AGRICULTURAL UNIVERSITY HISAR-125004, HARYANA	
Phone:01662-255447	e-mail: fpm@hau.ernet.in http://hau.ernet.in hau.machinerytesting@gmail.com	

SPECIFICATION SHEET OF TRACTOR OPERATED GROUNDNUT DIGGER

1.	Name of machine	:	
2.	Name and address of manufacturer	:	
3.	Selling price in India	:	

4. SPECIFICATIONS			
(Appendix A, Clause 3.2 and 6.1, IS:11235-2006)			
4.1	General:		
	a) Name	:	
	b) Type	:	
	c) Make	:	
	d) Serial Number	:	
	e) Model	:	
	f) Year of manufacture	:	
	g) Recommended source of power as per applicant	:	
4.2	Constructional Details:		
4.2.1	Main frame:		
	a) Type and material	:	
	b) Size (mm)	:	

4.2.2	Blade:		
	a) Type and Material	:	
	b) Number	:	
	c) Size (mm)	:	
	d) Inclination angle	:	
	e) Clearance from ground (mm)	:	
	f) Clearance from main frame (mm)	:	
	g) Method of fixing	:	

4.2.3	Elevator chain conveyor :		
	a) Material and type	:	
	b) Size (mm)	:	
	Peripheral length	:	
	Width	:	
	c) Conveyor rack material and size (mm)	:	
	d) Spacing between racks (mm)	:	
	e) Number of racks	:	

	f)	Material, nos. and size (mm) of spikes on racks	:	
	g)	Slope of conveyor	:	
	h)	Method of power transmission	:	
4.2.4	Rear support / Depth control wheel:			
	a)	Type	:	
	b)	Number	:	
	c)	Size	:	
	d)	Spacing (mm)	:	
	e)	Hub diameter (mm)	:	
4.2.5	Safety features :			
	a)	PTO guard	:	
	b)	V-belt guard	:	
4.2.6	Type of hitch and its details :			
	a)	Type	:	
	b)	Constructional details	:	

Specification of Hitch Pyramid As per IS: 4468-1997 (Part-I)

Sr.	Dimension (Refer Fig.1)	Description	Measurement
Upper Hitch attachments			
1	d_1	Diameter of hitch pin hole	
2	$b\phi$	Width between inner faces of yoke	
3	$b\phi$	Width between outer faces of yoke	
Lower hitch points			
4	D_2	Dia. of hitch pin	
5	$b\phi_3$	Linch pin hole distance	
6	l	Lower hitch point span	
Other dimensions			
Diameter of linch pin hole			
7	d	For upper hitch pin	
8		For lower hitch pin	
9	h	Mast height	

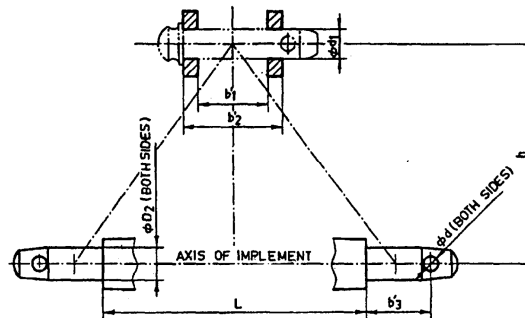

Fig. 3 : Implement Hitch Attachment

4.2.7 Power transmission system:

- a) Method of transmission :

4.2.7.1 Splined end of digger input shaft (Refer Fig. 4):

Sr.	Specification/ Notations (Refer Fig.2)	Measurement
1	PTO Type	
2	Nominal speed (rpm)	
3	Nominal dia.(mm)	
4	Number and type of splines	
Dimensions (mm)		
5	D	
6	d	
7	B	
8	A	
9	W	
10	a	
11	b	
12	c	
13	x	
14	B	
15	h	

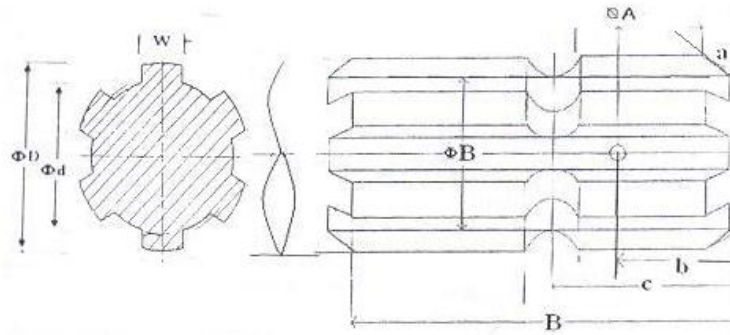

Fig. 4: Dimension of Implement Power Input Shaft

4.2.7.2	Gear box assembly (primary reduction):		
	a)	Type	:
	b)	No. of teeth on pinion	:
	c)	No. of teeth on bevel gear	:
	d)	Reduction ratio at gear box	:
	e)	Oil capacity (L)	:
	f)	Oil change period (hr)	:
	g)	Recommended grade of oil	:
	h)	Length of power transmission shaft (mm) (from gear box to front pulley)	:
	i)	Diameter of shaft (mm)	:
	j)	Provision of breather	:
4.2.7.3	Gear box to conveyor upper pulley (secondary reduction) :		
	a)	Front pulley diameter (mm)	:
	b)	Rear pulley diameter (mm)	:
	c)	V-belt size, number	:
	d)	Provision of belt tightening	:
	e)	Dia. of casing of output shaft (mm)	:
	f)	Dia. of rear drive shaft (mm)	:
4.2.7.4	Propeller shaft (Refer Fig. 5)		
	a)	Type and material	:

	b)	Length of shaft (mm)	:	
	c)	Mass of shaft (kg)	:	
	d)	Provision for locking	:	

Propeller Shaft Insert Dimensions As per IS: 4931-2006

Sr.	Notations (Refer Fig.3)	
1	D	
2	d	
3	W	
4	B	

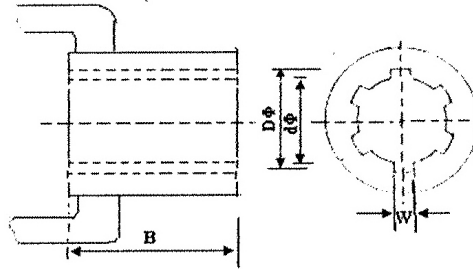

Fig. 5 : Propeller Shaft Insert Dimensions

4.2.8	Windrowing mechanism:		
	a)	Type and material	:
4.3	Overall Dimensions (mm):		
	a)	Length	:
	b)	Width	:
	c)	Height	:
	d)	Mass (kg)	:
4.4	Color of implement		:

4.5 Details of Material of Construction : (Cl. 6.1.1.(b) and 8.2 of IS:13818-1999)

Sr.	Name of part	Material
1	2	3
1	Frame	MS tubular pipe
2	Elevator racks	
3	Blade	
4	Main shaft	
5	Conveyor shaft	
6	Chain Sprocket	
7	Pulley	
8	Rear support/ Depth control wheel	

Place:
Date:

Signature: _____

Name : _____

Designation: _____